

COOLPIX 600

Nikon
DIGITAL
CAMERA
E 600
User's Manual



Nikon

Things You Should Know

Thank you and congratulations

on your purchase of this state of the art Nikon Digital Camera. This product has been manufactured and tested to Nikon's highest standards to give you the best in performance and reliability. **Save this operating instruction manual** as an operating and information guide.

Date of Purchase _____

Dealer Purchased From _____

Dealer Address _____

Dealer Phone No. _____

Model No. _____

Serial No. _____

Unpack your Digital Camera

Please confirm that the following items are packed in the Digital Camera box. They are provided to help you use or set up your Digital Camera.

1pc. Digital Camera
(COOLPIX 600)

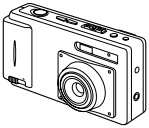

1pc. Digital Camera Station
(DS-60)

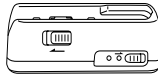

1pc. AC Adaptor
(EH-60)

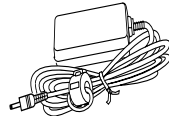

1pc. Dedicated
Ni-Cd Battery Pack



1pc. Hand Strap
(AH-E600)



1pc. Soft Carrying
Case
(CS-E600)



1pc. Detachable
Speedlight
(SB-E600)



1pc. Video Cable
(EG-60)

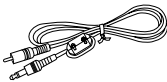

1pc. PC Connection Cable
for Windows
(SC-E600)

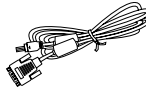

1pc. PC Connection Cable
Adaptor for Macintosh
(SC-E600M)



1 pc. Lithium
Battery



1 pc. CD-ROM of
Nikon View 600
Software for Windows
95 and Macintosh



1 pc. CD-ROM of
Adobe®
PhotoDeluxe™ 2.0



1 pc. 8 MB
CompactFlash
Card
(EC-8CF)



Microsoft, Windows, and Windows 95 are registered trademarks of Microsoft in the United States and other countries.

Macintosh is a registered trademark of Apple Computer Incorporated.

CompactFlash is a trademark of SanDisk Corporation.

All product/brand names are trademarks or registered trademarks of the respective holders.

Information

Note: This equipment has been tested and found to comply with the limits for a Class B digital device, pursuant to Part 15 of the FCC Rules. These limits are designed to provide reasonable protection against harmful interference in a residential installation. This equipment generates, uses and can radiate radio frequency energy and, if not installed and used in accordance with the instructions, may cause harmful interference to radio communications. However, there is no guarantee that interference will not occur in a particular installation. If this equipment does cause harmful interference to radio or television reception, which can be determined by turning the equipment off and on, the user is encouraged to try to correct the interference by one or more of the following measures:

- Reorient or relocate the receiving antenna.
- Increase the separation between the equipment and receiver.
- Connect the equipment into an outlet on a circuit different from that to which the receiver is connected.
- Consult the dealer or an experienced radio/TV technician for help.

FCC Warning: To assure continued FCC compliance, use only the provided shielded interface cable with ferrite cores when connecting digital camera station to computer. Also, any unauthorized changes or modifications to this equipment could void the user's authority to operate.

Notice for customers in Canada

CAUTION

This class B digital apparatus meets all requirements of the Canadian interference Causing Equipment regulations.

ATTENTION

Cet appareil numérique de la class B respecte toutes les exigences du Règlement sur le matériel brouilleur du Canada.

Precautions

USE & LOCATION

- **TO AVOID SHOCK HAZARD ...** Your Digital Camera and power supply should not be exposed to rain or moisture. Do not connect the power supply or operate your Digital Camera if it gets wet. Your Digital Camera has been designed for outdoor use, however it is not designed to sustain direct exposure to water, rain, sleet, snow, sand, dust, or a direct splashing from a pool or even a cup of coffee. This action could permanently damage the internal parts of your Digital Camera. Do not attempt to disassemble this unit. There are no user serviceable parts inside. Unplug your Digital Camera from the power supply and have it serviced.
- **DO NOT AIM YOUR DIGITAL CAMERA AT THE SUN OR OTHER BRIGHT OBJECTS.**
- **DO NOT EXPOSE YOUR DIGITAL CAMERA TO EXTENDED HIGH TEMPERATURE ...** Such as, in direct sunlight, inside a closed car, next to a heater, etc... This action could permanently damage the internal parts of your Digital Camera.
- **AVOID SUDDEN CHANGES IN TEMPERATURE ...** If the unit is suddenly moved from a cold place to a warm place, moisture may form inside the unit.
- **DO NOT LEAVE YOUR DIGITAL CAMERA OR THE POWER SUPPLY TURNED ON WHEN NOT IN USE.**
- **STORAGE OF YOUR DIGITAL CAMERA ...** Store and handle your Digital Camera in a manner that will not subject it to unnecessary movement (avoid shaking and striking). Your Digital Camera contains a sensitive pick-up device which could be damaged by improper handling or storage.

CARE

- **TO CLEAN YOUR DIGITAL CAMERA ...** Do not use strong or abrasive detergents when cleaning your Digital Camera body.
- **TO PROTECT THE LENS ...** Do not touch the surface of the lens with your hand. Use a commercial Digital Camera lens solution and lens paper when cleaning the lens. Improper cleaning can scratch the lens coating.
- **TO PROTECT THE FINISH OF YOUR DIGITAL CAMERA ...** Before handling your Digital Camera, make sure your hands and face are free from any chemical products, such as suntan lotion, as it may damage the finish.

Table of Contents

Things You Should Know	2
Information	3
Index of Controls	5
Attaching the Hand Strap/Soft Carrying Case	7
Power Supply	8
Setting the Clock	11
Using the Speedlight	12
Adjusting LCD Viewfinder Brightness	14
Adjusting the Iris Manually	15
On Screen Display (OSD)	16
CompactFlash Card	17
Capturing Images	18
Capturing Close-up Images (macro)	21
Playing Back Captured Images	22
To Delete Specific Images	27
To Delete All Image Pages	28
Viewing Images on Your TV Screen	29
Transferring Your Images (VCR)	30
Inserting the PCMCIA Adapter	31
Transferring Your Images (Windows 95)	32
Transferring Your Images (Macintosh)	35
Before Requesting Service	37
Specifications	38
Index	39

Index of Controls

Front View

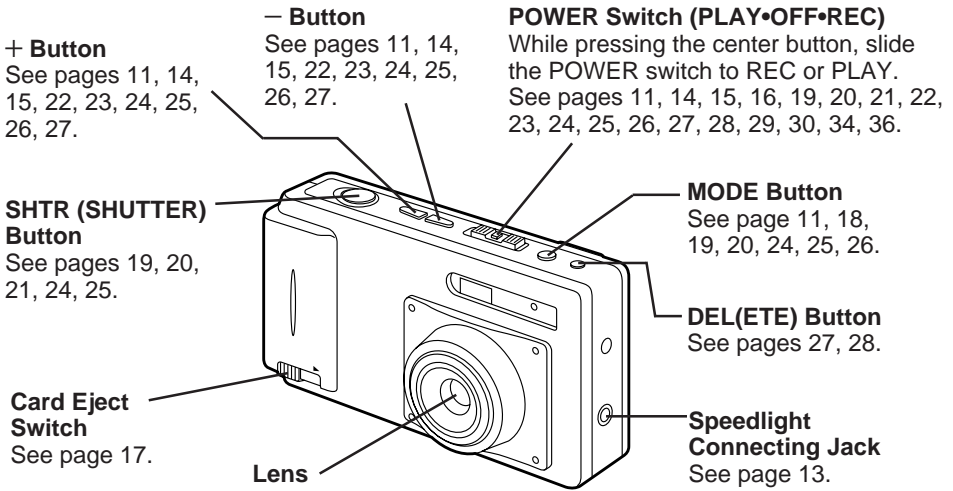

Rear View

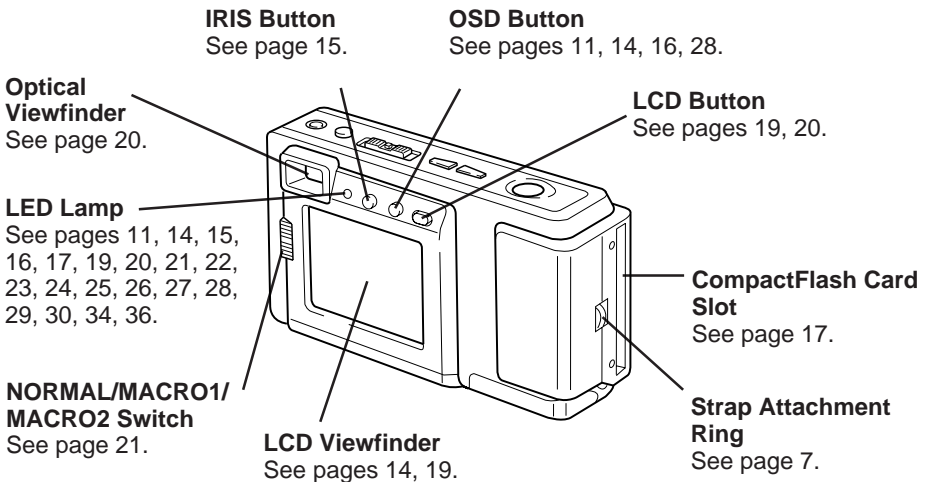

Underside View

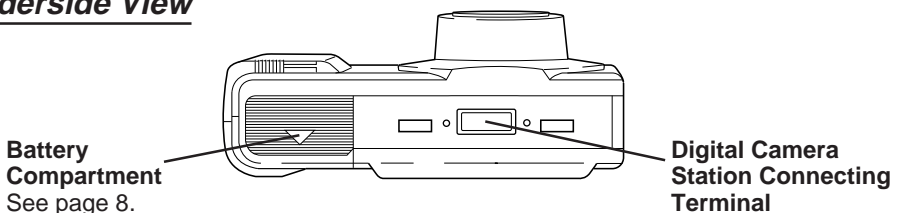

Index of Controls

AC Adaptor

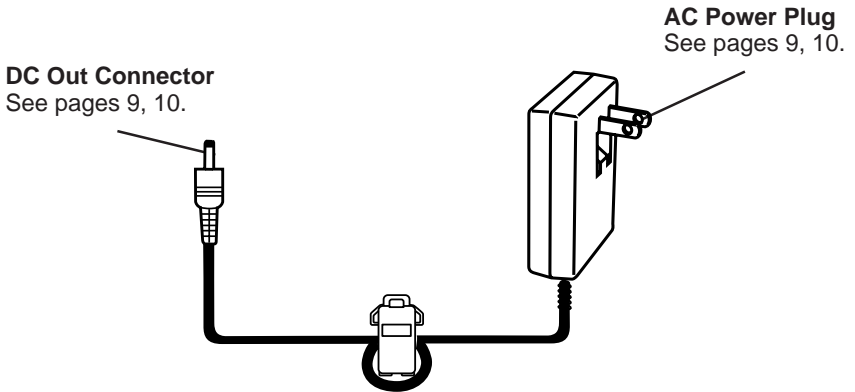

Digital Camera Station (Front View)

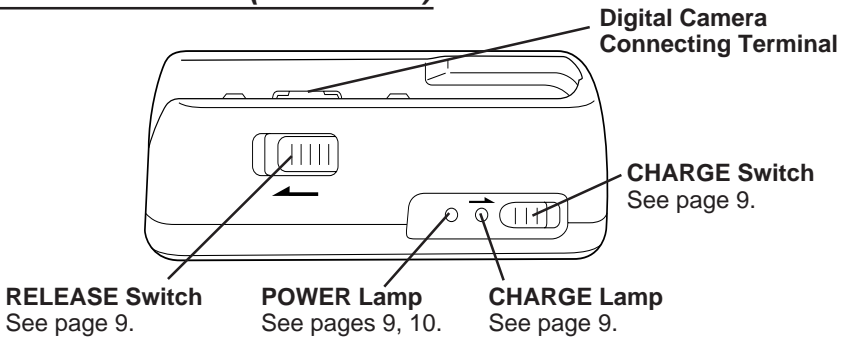

Digital Camera Station (Rear View)

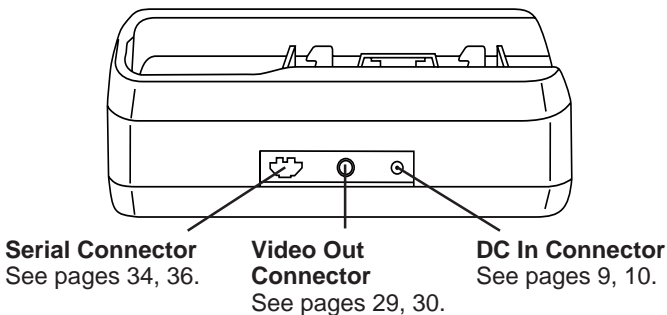

Index of Controls

Detachable Speedlight

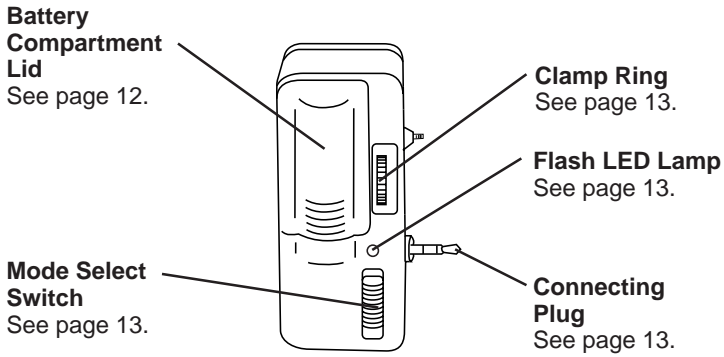

Attaching the Hand Strap/Soft Carrying Case

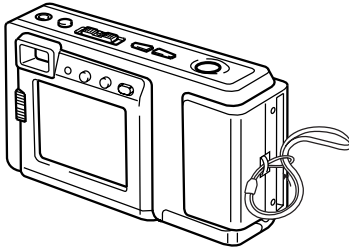

Thread the Hand Strap through the Strap Attachment ring as shown.

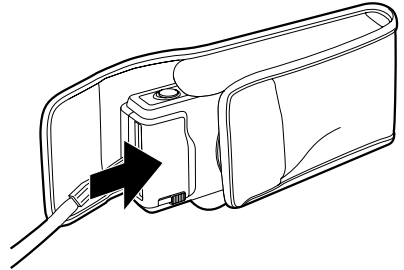

Keep the Digital Camera in the Soft Carrying Case as shown when not in use.

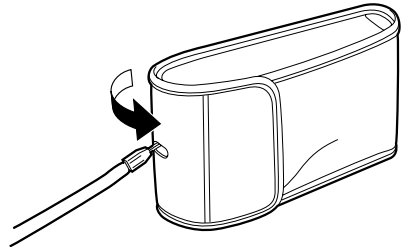

You may thread the hand strap through the hole in the Soft Carrying Case.

Power Supply

Loading the Ni-Cd Battery Pack

Underside

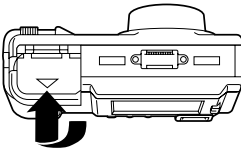
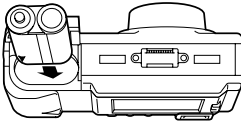
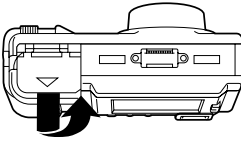

1 Slide the Battery Compartment lid in the direction of the arrow and swing it open.

2 Install the Battery Pack with the arrow mark at the bottom and facing the rear of the Digital Camera.

3 Swing the Battery Compartment lid down and slide it shut.

- Charge the Battery Pack fully before operation (see page 9).

WARNING! Do not dispose of in fire, put in backwards, disassemble, or short circuit; otherwise battery may leak or burst, causing possible personal injury.

Battery Pack Notes

Caution:

- Charge only with specified charger.
- The Battery can be charged within a temperature range of 32° F (0° C) and 104° F (40° C).
- The Battery Pack may be warm after charging or just after use. This is normal.
- Do not use an insufficiently charged or worn out Battery Pack.

Safety precautions:

- Do not get the Battery Pack or AA alkaline batteries near, or dispose of in fire.
- Do not directly connect (short circuit) the positive (+) and negative (-) terminals.
- Never attempt to disassemble or reassemble the Battery Pack.

To avoid damage to the Battery Pack:

- Do not drop or jar the Battery Pack.
- Use the Battery Pack with specified units only.

To insure longer Battery Pack life:

- While not in use, remove the Battery Pack from the Digital Camera and store in a dark, cool, dry place.
- Keep the Battery Pack terminals clean.

CAUTION

Discharge the remaining voltage of the Battery Pack completely before charging. This is vital to maintain battery life and the operation time due to characteristics of the battery.
Do not remove the Digital Camera while charging is in progress.

U.S.A. CONSUMERS:

ATTENTION:

The product you have purchased is powered by a nickel cadmium battery which is recyclable. At the end of its useful life, under various state and local laws, it is illegal to dispose of this battery into your municipal waste stream. Please call 1-800-8-BATTERY for information on how to recycle this battery.



Power Supply

Charging the Battery Pack

Install the Battery Pack (see page 8.)

Charge the Battery Pack fully before operation.

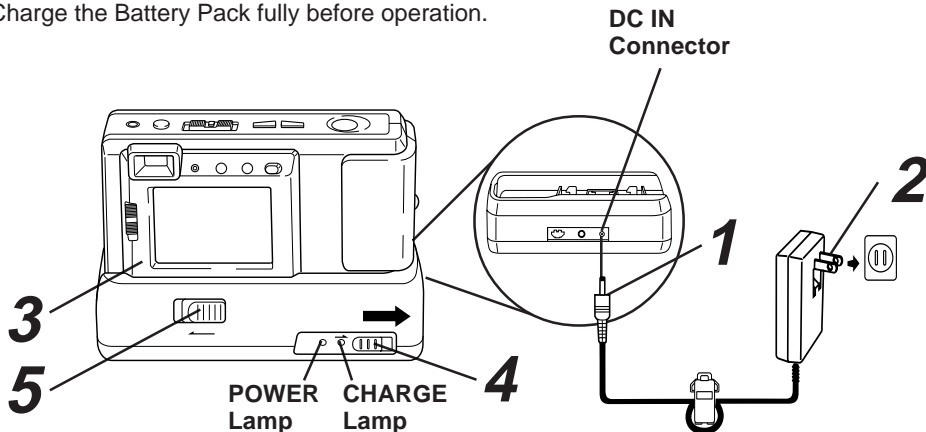

1 Connect DC OUT on the AC Adaptor to DC IN on the Digital Camera Station until it locks with a click.

2 Plug the AC Adaptor into an AC outlet.
The POWER Lamp lights up.

3 Insert the Digital Camera into the Digital Camera Station until it locks.

4 Slide the CHARGE switch.
The CHARGE Lamp lights orange, and then changes to green when charging is done (just under 2.5 hours).

- A red CHARGE Lamp indicates a charge malfunction. Remove the Digital Camera and repeat steps 3 and 4. If the CHARGE Lamp is still red, send the unit in for service.

5 Slide the RELEASE switch to release the Digital Camera from the Digital Camera Station.

- With a fully charged Battery Pack, you will have a maximum of about 50 minutes*¹ of continuous playback(77°F/25°C).

*¹ When playback 1 image every 60 seconds.

- The useful operation time of the Battery will gradually decrease after repeated use and recharging. The Battery is no longer serviceable if the operation time is very short, even after a sufficient charge.
- Instead of the supplied Battery Pack, you can also use AA type Lithium batteries*², Ni-Cd (high density type) or nickel-hydride batteries available on the market.

*² In places where the temperature is 50°F(10°C) and below, the battery's characteristic use time is shortened. A exclusive nickel-cadmium battery pack is recommended in lower temperatures.

- For emergency use you can install 2 alkaline batteries. But, due to power consumption and shorter operation life of alkaline batteries compared to the supplied rechargeable battery pack, it is strongly recommended that only the Optical Viewfinder (turn off the LCD Viewfinder) be used to capture images when using alkaline batteries.
- If you are not going to use the Digital Camera for an extended period of time, remove the Battery Pack from the Digital Camera.

Power Supply

AC Adaptor

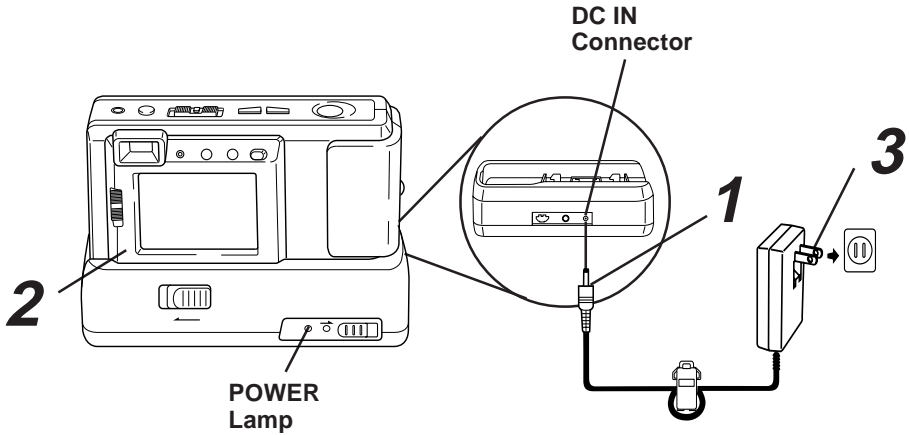

1 Connect DC OUT on the AC Adaptor to DC IN on the Digital Camera Station until it locks with a click.

2 Insert the Digital Camera into the Digital Camera Station until it locks.

3 Plug the AC Adaptor into an AC outlet.

- The POWER Lamp lights up.

Note:

- While not in use, unplug the AC Adaptor from the AC outlet.

Setting the Clock

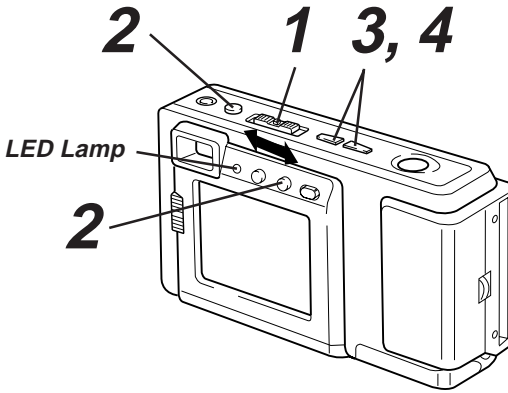

1 Set the **POWER** switch to **REC** or **PLAY**.

- The LED Lamp lights up.

2 Press **OSD** and **MODE** at the same time to display the clock set screen.

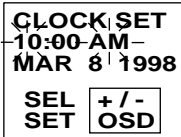

3 Press **(+)** or **(-)** to select the correct hour, then press **OSD** to set.

4 Repeat **step 3** to select and set the correct minute, month, date, and year.

- Double check all items before setting the year.

Note:

- To make corrections, repeat steps 2-4.
- The clock will continue to operate about 8 hours after the battery has been removed. If you need to reset the clock, repeat steps 2-4.

Using the Speedlight

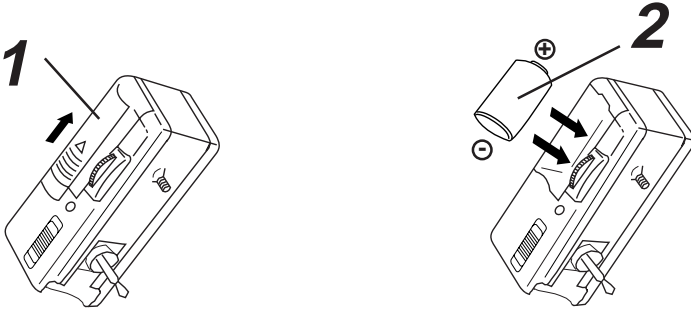

Install the battery

1 Open the Battery Compartment lid by sliding it in the direction of the arrow, as shown above.

2 Install the battery as indicated inside the Battery Compartment.

- Do not reverse the battery polarities (–) and (+). Incorrect use may shorten battery life, causing the battery to become hot, leak or explode.
- Make sure the battery is firmly in place to avoid a loose connection.

Remove the battery

- Pull up the string in the battery compartment and remove the battery.

CAUTION

Replace with CR2 Lithium batteries only. Use of another battery may present a risk of fire or explosion. Caution-battery may explode if mistreated.

Fire and burn hazard. Do not recharge, disassemble, or dispose of in fire.

Keep battery out of reach of children.

Danger of explosion if battery is incorrectly inserted. Dispose of used battery promptly.

When disposing of the used Lithium Battery be sure to insulate the battery polarities (+) and (–) by covering with cellophane tape.

Using the Speedlight

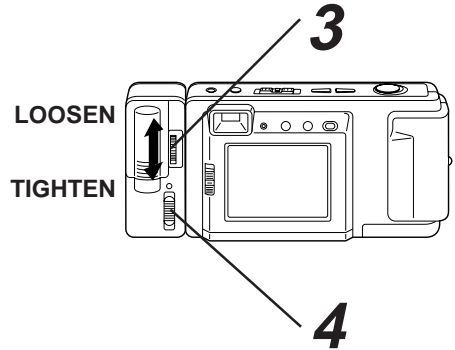
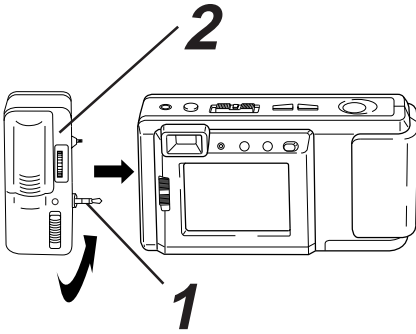

Attaching the Speedlight

- 1** Pull up on the connecting plug from its retracted position as shown above.
- 2** Connect to the digital camera connecting jack.
- 3** Rotate thumbwheel to secure the speedlight.
 - Be sure to set the Digital Camera and the speedlight unit to OFF before attaching or removing the speedlight.

Using the Speedlight

- 4** Slide the **MODE Select Switch** to one of the following positions to use the speedlight.
 - **AUTO** The speedlight automatically lights depending on lighting conditions.
 - **⚡** The speedlight will light whenever you capture an image.
 - **OFF** The speedlight will not light even when you capture an image.

NOTE:

- Please set the **MODE Select Switch** to OFF when taking Macro shots (see page 21).
- The LED Lamp on the speedlight unit lights when speedlight is charged and ready.
- The effective range of the speedlight is roughly 3.3 feet (1m) to 8.2 feet (2.5m).
- If you are using the speedlight in very bright areas, the image background may become dark.
 - While not in use, remove the battery from the speedlight.
 - Remove the speedlight when not in use.
 - Never handle the speedlight if your hands are wet. This may result in electric shock or damage to the speedlight.
 - Do not use the speedlight close to people's faces as it may be harmful to the eyes. Especially when capturing images of infants or small children, keep at least 3.3 feet (1m) away.

Adjusting LCD Viewfinder Brightness

You may want to brighten or darken the LCD (Liquid Crystal Display) Viewfinder for easier viewing. This adjustment will not affect the captured image brightness.

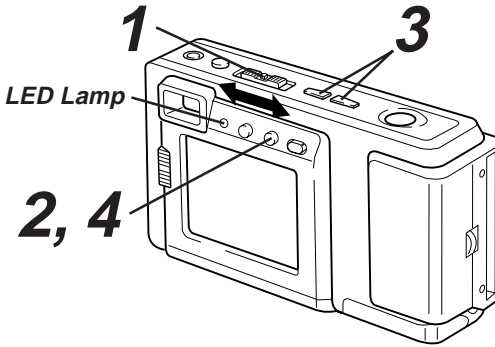

1 Set the **POWER** switch to **REC** or **PLAY**.

- The LED Lamp lights up.

2 Press **OSD** repeatedly until the **BRIGHT** adjustment screen appears.

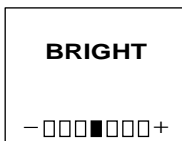

3 Press **(+)** or **(-)** to change the brightness of the LCD Viewfinder; **(+)** for brighter, **(-)** for darker.

- The normal screen will reappear if either **(+)** or **(-)** is not pressed within 5 seconds.

4 Press **OSD** once to exit the **BRIGHT** adjustment screen.

Note:

- The **BRIGHT** adjustment will be reset to the original setting when the Digital Camera is turned off.

Adjusting the Iris Manually

Normally, the camera adjusts the exposure automatically. However, when the background is extremely bright, or when the subject is backlit, you can compensate by adjusting the Iris manually.

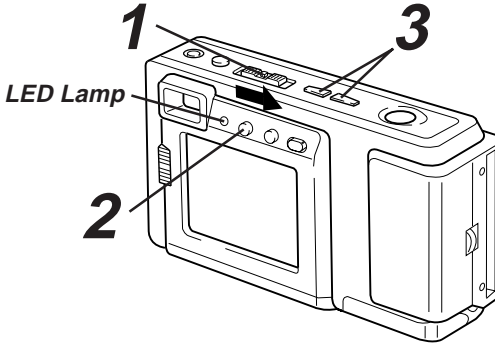

1 Set the POWER switch to REC.

- The LED Lamp lights up.

2 Press IRIS Button to display the IRIS screen.

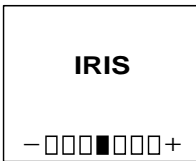

3 Press (+) or (-) to change the IRIS; Press (+) to increase the brightness, Press (-) to decrease the brightness.

- The IRIS screen disappears about 5 seconds after the adjustment.

Note:

- There are 7 brightness compensation levels ranging from -3 to +3.
- A blue sky may appear somewhat whiter when the brightness is increased.
- The brightness cannot be adequately compensated for in extreme backlight conditions.
- The original exposure is automatically restored when the power is turned off.

On Screen Display (OSD)

The indications displayed on the LCD screen will tell you the operation status of the Digital Camera.

REC Mode

Function Status

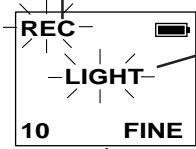
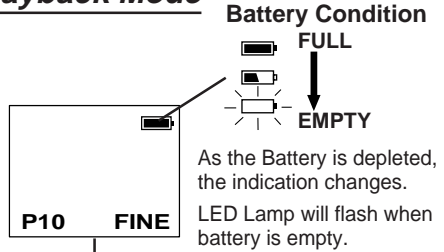

Image Pages left in memory and Image Resolution selected; FINE (Fine), NORMAL (Normal), ZOOM (Zoom), WIDE (Wide), or MULTI (Multi).

Low Light Warning

"LIGHT" will appear when the light level is inadequate. In this case, more light should be provided or use speedlight (See page 13) to achieve better picture quality and color.

Playback Mode



Displayed Image Page and its Image Resolution FINE (Fine), NORMAL (Normal), or WIDE (Wide).

- If the image is captured in ZOOM mode, the displayed Image Resolution will be NORMAL.
- If the image is captured in MULTI mode, the displayed Image Resolution will be FINE.

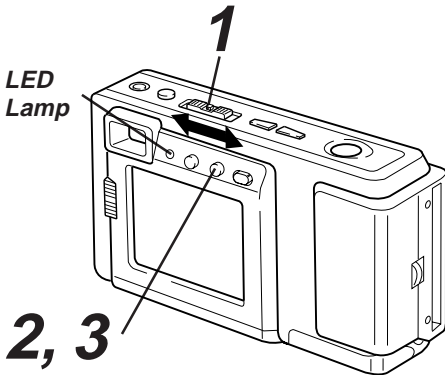

To Cancel the OSD

1 Set the POWER switch to REC or PLAY.

- The LED Lamp lights up.

2 Press OSD repeatedly until the On Screen Display disappears.

3 To resume the On Screen Display, press OSD until it reappears.

- Only Warning indications and REC indication will be displayed on the LCD Viewfinder if the OSD is cancelled.
- The OSD feature will be in on mode each time the Digital Camera is powered on.

On Screen Display Order

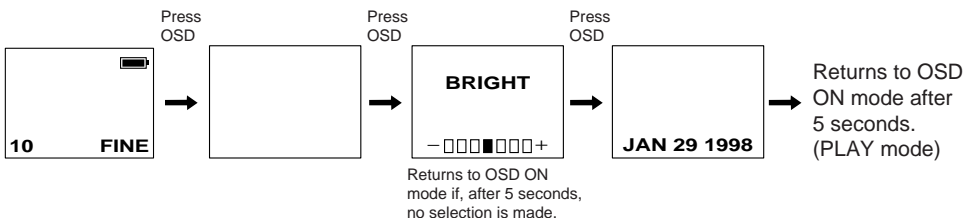

CompactFlash Card

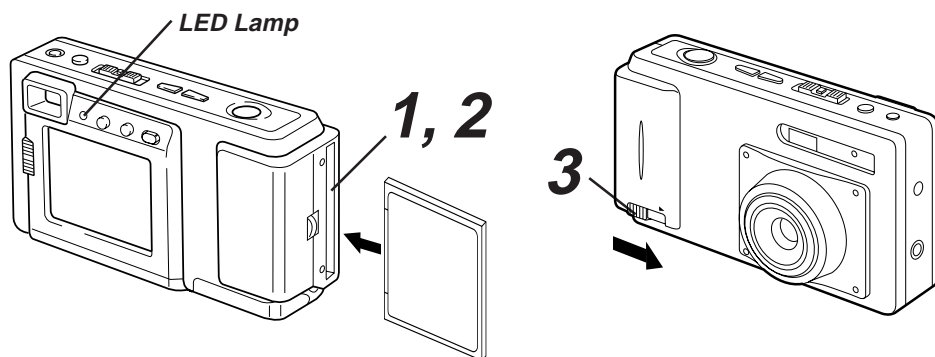

Inserting the CompactFlash Card.

- The captured images will be stored on this CompactFlash Card.
- Be sure to insert the CompactFlash Card before using the camera.

1 Insert the CompactFlash Card into the slot in the direction of the arrow mark and so that the arrow mark side of the card faces the front (lens Side) of the Digital Camera.

2 Push the card fully into the CompactFlash Card Slot.

Removing the CompactFlash Card.

3 Slide the CARD EJECT Switch, so the Card pops out. (Be careful not to drop the card.)

- We recommend using the Nikon CompactFlash Card with this camera; EC-8CF 8MB (included), or EC-4CF 4MB, EC-10CF 10MB, EC-24CF 24MB (optional). Other cards may not perform to specifications.

- Do not, under any circumstances, eject the card immediately after pressing the Shutter Button (during recording of an image) or while deleting (when PLEASE WAIT is displayed). This could damage the format of the card and make it unusable.
- Make sure that you do not insert the card in the wrong direction.
- When the card does not eject after pressing the CARD EJECT Switch, push the card fully into the slot again and then press the CARD EJECT Switch firmly.
- To avoid dropping the card, do not push the CARD EJECT Switch when the card slot is facing downward.
- NO CF CARD will appear on the LCD Viewfinder and the LED Lamp will flash when the CompactFlash Card is not inserted.
- CF CARD ERROR will appear on the LCD Viewfinder and the LED Lamp will flash if the CompactFlash Card is defective.

Capturing Images

MODE Button

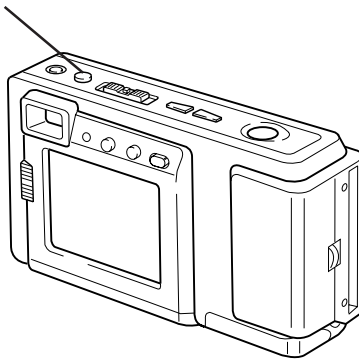

To Select the Recording Mode

You can select the recording mode by pressing the MODE switch.

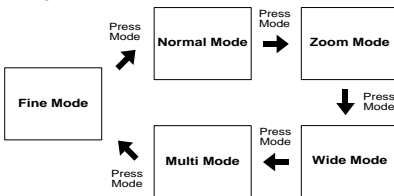

- The recording mode can be switched anytime by pressing MODE.

Fine Mode

- Image resolution is 1,024 X 768.
- Approx. 30 images can be stored with supplied 8 MB CompactFlash Card.

Normal Mode

- Image resolution is 512 X 384.
- Approx. 100 images can be stored with supplied 8 MB CompactFlash Card.

Zoom Mode

- Using Zoom mode magnifies the image to twice its normal size.
- Image resolution is 512 X 384.
- Approx. 100 images can be stored with supplied 8 MB CompactFlash Card.

Note :

Picture quality of images captured in ZOOM mode are less than those captured in NORMAL mode.

Wide Mode

- Image resolution is 1,136 X 640.
- Approx. 30 images can be stored with supplied 8 MB CompactFlash Card.



Multi Mode

- Pressing SHUTTER in Multi mode allows you to capture an image every 0.3 seconds to create a series of nine shots. The images are displayed in order from the upper left corner on the screen.
- Image resolution is 1,024 X 768.
- Approx. 30 images can be stored with supplied 8 MB CompactFlash Card.

A	B	C
D	E	F
G	H	I

Note :

If SHUTTER is held down and then released, the images may not be displayed in the order shown above.

Capturing Images

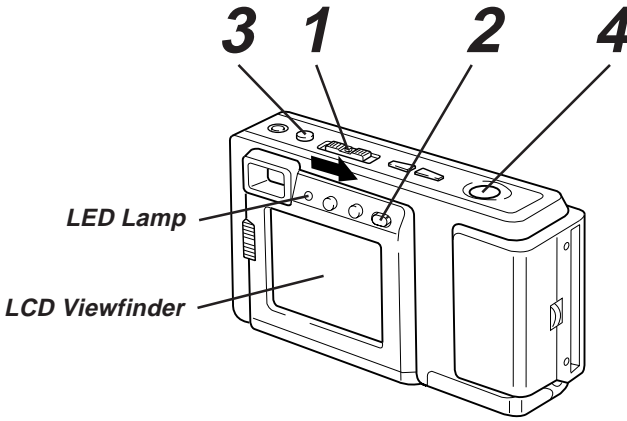

Using LCD Viewfinder

- 1** Set the **POWER** switch to **REC**.
Make sure you slide the **POWER** switch fully to the **REC** position.
- The **LED Lamp** lights up.



- 2** Make sure the **LCD Viewfinder** is on.
Press the **LCD** button if the **LCD Viewfinder** is off.

- 3** Press **MODE** to select the recording mode. (See page 18.)

- 4** Press **SHTR (SHUTTER)** to capture the image displayed on the **Viewfinder**.
- Press **SHTR(SHUTTER)** down halfway to lock **Auto Focus**.

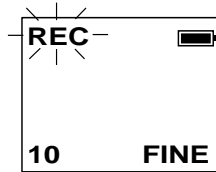

- **REC** on the **LCD Viewfinder** and **LED Lamp** will flash while the **Digital Camera** processes the image. You may capture another image as soon as **REC** and **LED Lamp** stops flashing.

Capturing Images

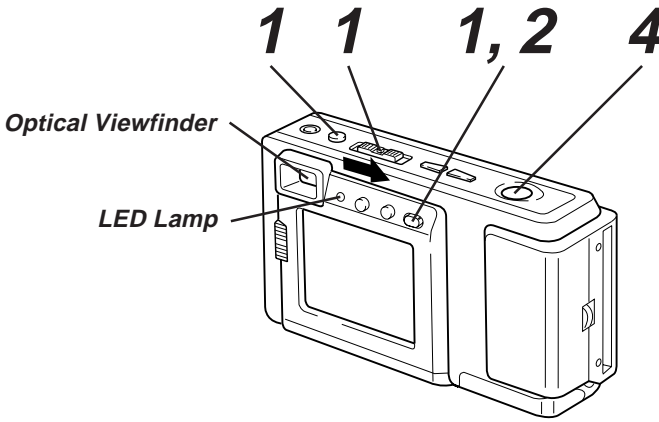

Using Optical Viewfinder

1 Repeat step 1 and 3 on the previous page.

2 Press the **LCD** button to turn off the LCD Viewfinder.

- If you press the OSD or MODE button, the LCD monitor will turn on.

3 Frame the image you want to capture within the recording area guide marks on the Optical Viewfinder.

Normal

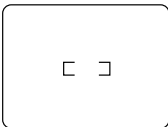

Short Distance

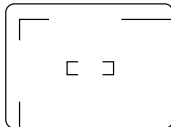

- Please use the Short Distance frame when capturing images within 3.3 feet (1 m) of subject.
- Focus will be adjusted automatically in the center mark area.

4 Press **SHTR (SHUTTER)** to capture the image.

- LED Lamp will flash while the Digital Camera processes the image. You may capture another image as soon as LED Lamp stops flashing.

- Using the Optical Viewfinder will prolong battery life.

Notes for LCD and Optical Viewfinder use:

- The number of image pages left in the selected mode is displayed on the LCD Viewfinder. When no memory remains, 0 and LED Lamp will flash. To capture other images, you will first need to delete some images from memory (see pages 27, 28).
- The Digital Camera is focused automatically. For close-ups, see page 21.
- If, after the POWER switch has been set to REC or PLAY, no buttons are pressed for one minute in REC mode or two minutes in PLAY mode, the LCD will turn off automatically to conserve power. To resume operation, press SHTR (SHUTTER), or set the POWER switch to OFF, and then to REC.
- Avoid covering the lens with your fingers when capturing images.
- Do not subject the LCD Viewfinder to pressure or shock.
- Hold the Digital Camera as steady as possible when capturing an image.
- The active LCD Viewfinder image will have a slightly degraded appearance when compared to a captured or transferred image. This is normal.

Capturing Close-up Images (macro)

You can capture images of plants, insects, photo album pictures, and so on.

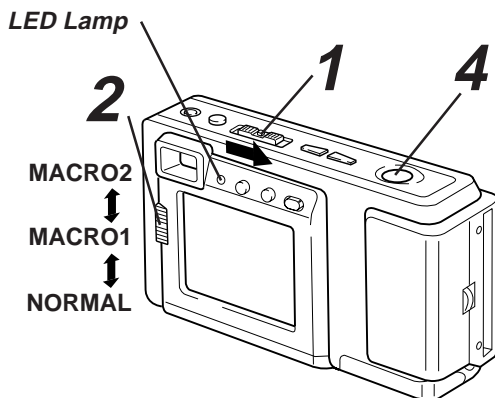

1 Set the **POWER** switch to **REC.**

- The LED Lamp lights up.

2 Set the **NORMAL/MACRO1/MACRO2** switch to **MACRO1** or **MACRO2**.

- LCD Viewfinder will turn on automatically.

3 Bring the **Digital Camera** up to the **subject** [as close as approximately 10.6 inches (27cm) away in **MACRO1** or 5.5 inches (14cm) away in **MACRO2**].

4 Press **SHTR (SHUTTER)** when the subject is in focus.

- The LED Lamp will flash while the Digital Camera processes the image.
- The flash will not light when the unit is in **MACRO** mode.
- You may have to move the Digital Camera closer or further away from the subject for proper focus
- When finished with this feature, be sure to return the **NORMAL/MACRO1/MACRO2** switch to **NORMAL**.

Playing Back Captured Images

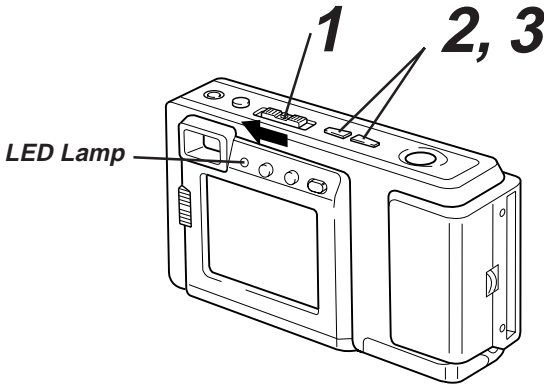

Manual Playback

1 Set the **POWER** switch to **PLAY**.

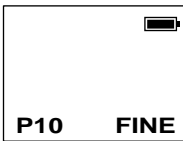

- The LED Lamp lights up.
- Turn off the LCD monitor when not in use by pressing the LCD button. To turn the monitor back on, press the LCD button again.
- If you press the DEL, OSD, or MODE button while in Play mode, the LCD monitor will automatically turn on as a warning.

2 Press **(+)** or **(-)** repeatedly, [(+) for ascending order, and (-) for descending order] to change the displayed image on the LCD Viewfinder.

- The image page number and resolution mode are displayed at the bottom of the screen.
- If there are no images in memory, a blue back screen will be displayed.

3 Hold down **(+)** or **(-)**, [(+) for ascending order, and (-) for descending order] to change the displayed image on the LCD Viewfinder by fast page advance.

- Page number is changed continuously while **(+)** or **(-)** button is held down.
- Selected page is displayed when button is released.

Playing Back Captured Images

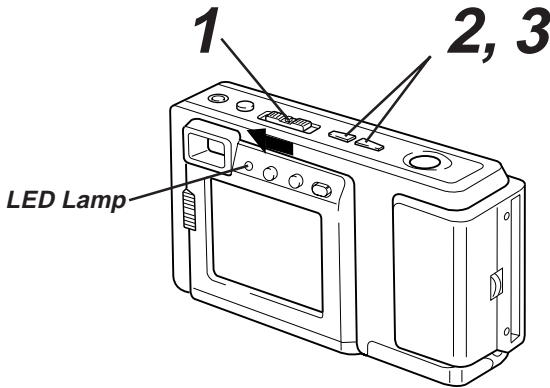

Auto Playback

1 Set the **POWER** switch to **PLAY**.

- The LED Lamp lights up.

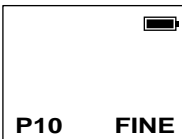

2 Hold down **(+)** and **(-)** at the same time to place the Digital Camera in Auto Playback mode.



- "AUTO PLAY START" will be displayed.
- Auto Play displays images in ascending order only.
- Each image will remain on the LCD Viewfinder for three seconds after it is fully displayed.
- Auto Play will continue to loop through the images until you cancel this feature.

3 Press **(+)** or **(-)** again to cancel Auto Playback mode.

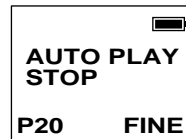

- "AUTO PLAY STOP" will be displayed.

Playing Back Captured Images

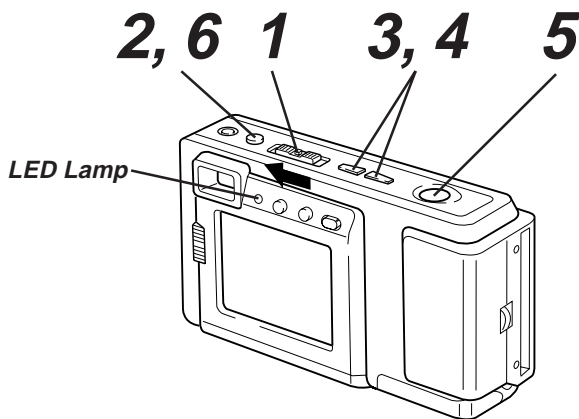

Multi Image Playback

- 1 Set the **POWER** switch to **PLAY**.
 - The LED Lamp lights up.

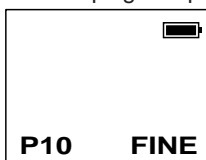

- 2 Press the **MODE** button. A Multi Image Playback screen will appear.
- 3 Press **(+)** repeatedly to scroll forward through Multi Image pages (each page contains nine images). When you locate the page containing the image you want, go to step 5. The selected image will be the one displayed on the screen.

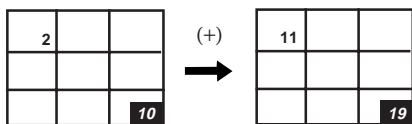

- 4 Press **(-)** to move back through the images on the page until the number of the image you want is selected.

- The number of the selected image will be inversely displayed.

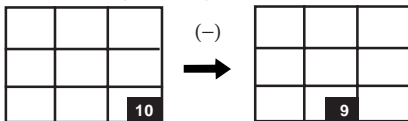

- 5 Press **SHTR (SHUTTER)**. The image you selected will be the one displayed on the screen.
- 6 Press **MODE** to restore the Multi Image Playback screen.

Select Playback Mode

Note:

- Press **MODE** repeatedly to select the desired playback mode as shown below.

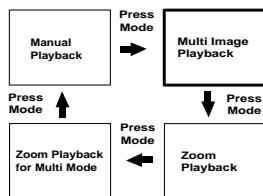

Playing Back Captured Images

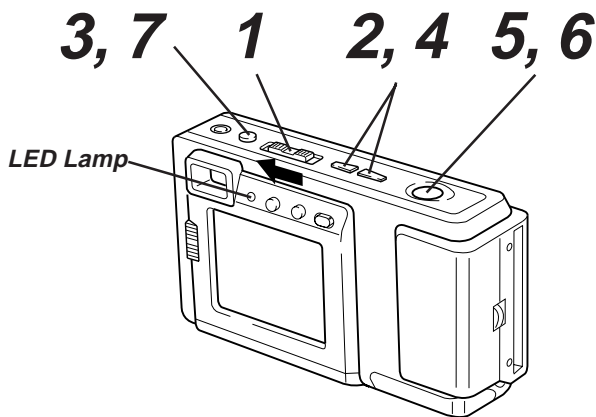

Zoom Playback

- 1** Set the **POWER** switch to **PLAY**.
 - The LED Lamp lights up.

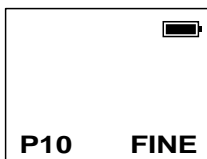

- 2** Press **(+)** or **(-)** to select the image you want to zoom in on.
- 3** Press **MODE** twice to enter the Zoom Playback mode.
- 4** Press **(+)** or **(-)** to select the desired Zoom Position.

Changing the Location of the Zoom Area.

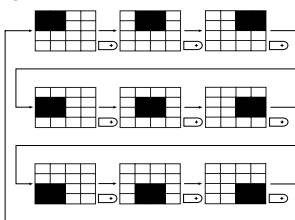

- Pressing **(-)** moves the zoom area in the opposite direction.

- 5** Press **SHTR (SHUTTER)** to zoom in on the selected portion of the image X2.
 - Press **(+)** or **(-)** to change the zooming area.

- 6** Press **SHTR (SHUTTER)** to restore the image to its normal size.

- 7** Press **MODE** twice to resume the normal screen.

Select Playback Mode

Note:

- Press **MODE** repeatedly to select the desired playback mode as shown below.

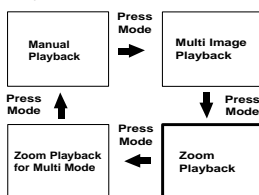

Playing Back Captured Images

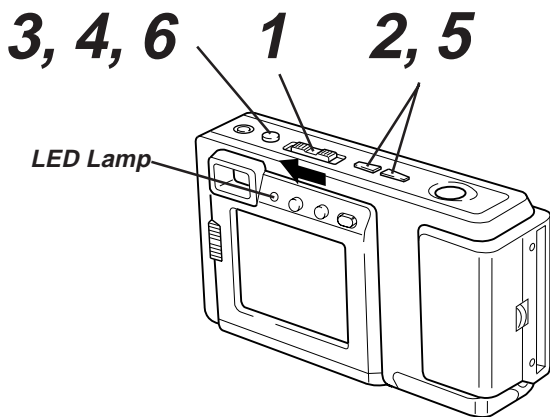

Zoom Playback for Multi Mode

1 Set the **POWER** switch to **PLAY**.

- The LED Lamp lights up.

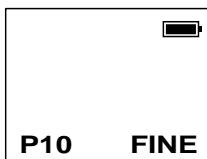

2 Press **(+)** or **(-)** to select the Multi Mode Image you want to zoom in on.

- You can also zoom the Normal Mode Image.

3 Press **MODE** three times to select Zoom Playback for Multi Mode.

4 Then the upper left image will be zoom in on.

- The image will be displayed X3 magnification.

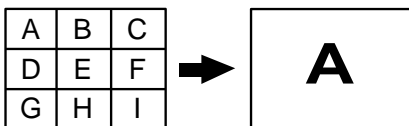

5 Press **(+)** or **(-)** to select a new image.

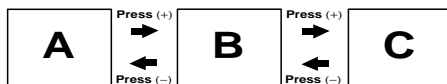

6 Press **MODE** to return to the normal screen.

To Select Playback Mode

Note:

- Press **MODE** repeatedly to select the desired playback mode as shown below.

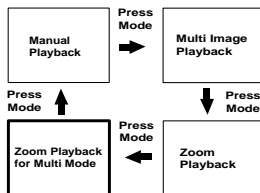

To Delete Specific Images

You can delete unwanted images and increase the remaining image memory.

Warning: Once deleted, images cannot be restored.

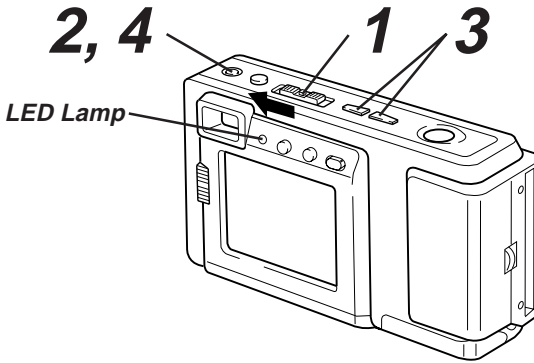

1 Set the POWER switch to PLAY.

- The LED Lamp lights up.

2 Press DEL to display the DELETE menu.

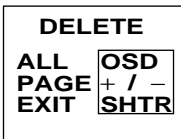

- To exit this menu, press SHTR.

3 Press (+) or (-) to select the image page to be deleted.

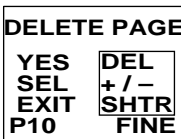

- To exit this menu, press SHTR.

4 Press DEL to select YES when the image page you want to delete is displayed.

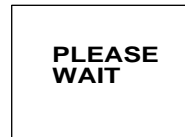

- Image page numbers are adjusted automatically as images are deleted.
- To delete other specific image pages, please repeat steps 2–4.

Important:

- While "PLEASE WAIT" is displayed, **do not turn off the Digital Camera nor unplug the AC Adaptor** because this will cause irreversible damage to the memory, resulting in reduced image storage capacity.

To Delete All Image Pages

You can delete all images from memory with one easy operation.

Warning: Once deleted, images cannot be restored.

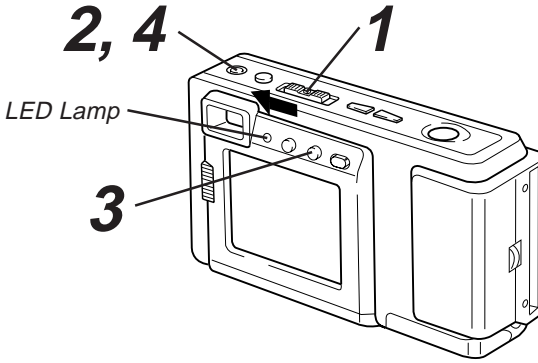

1 Set the POWER switch to PLAY.

- The LED Lamp lights up.

2 Press DEL to display the DELETE menu.

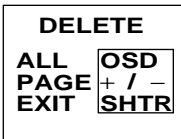

- To exit this menu, press SHTR.

3 Press OSD to select ALL in the DELETE menu.



- To exit this menu, press SHTR.

4 Press DEL to select YES in the DELETE ALL menu.

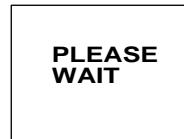

- "PLEASE WAIT" will be displayed on screen as all images are deleted from memory. Deletion is complete when the screen turns solid blue.

Important:

- While "PLEASE WAIT" is displayed, **do not turn off the Digital Camera nor unplug the AC Adaptor** because this will cause irreversible damage to the memory, resulting in reduced image storage capacity.

Viewing Images on Your TV Screen

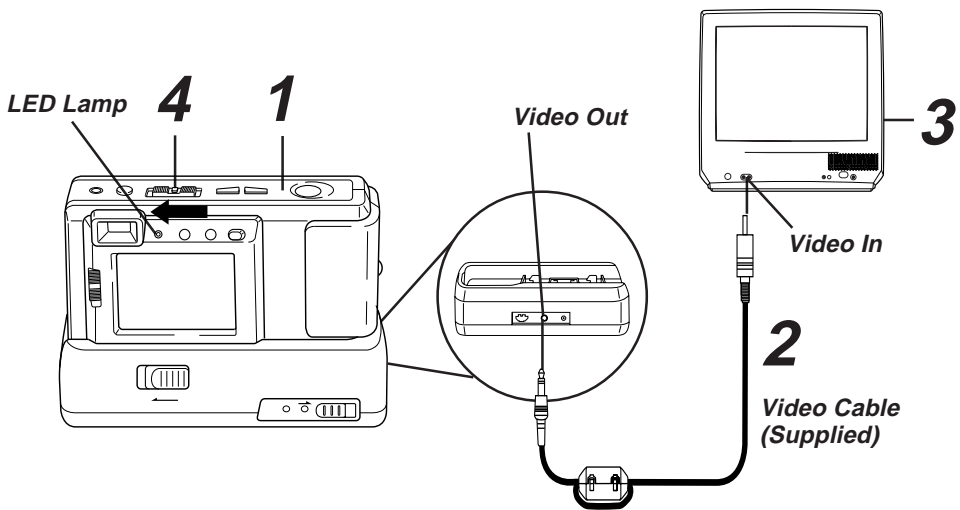

1 Insert the Digital Camera into the Digital Camera Station until it locks.

2 Connect the Digital Camera Station to your TV using the Video cable (supplied) as shown.

3 Turn on your TV and select its video input mode.

4 Set the Digital Camera **POWER** switch to **PLAY**. You may select manual or auto playback as described on pages 22 and 23.

- The LED Lamp lights up.

Note:

- For extended periods of use, it is recommended to use the AC Adaptor for a power source.

Transferring Your Images (VCR)

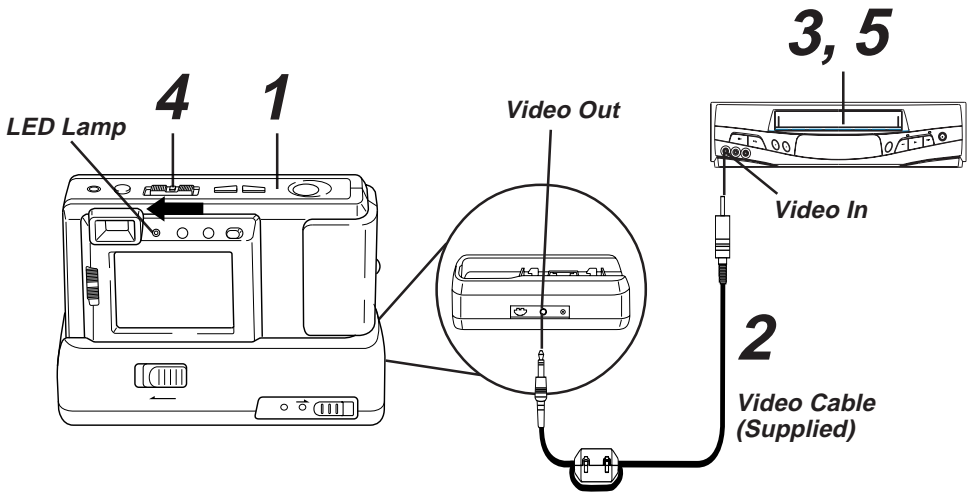

1 Insert the Digital Camera into the Digital Camera Station until it locks.

2 Connect the Digital Camera Station to your VCR using the Video cable (supplied) as shown.

3 Turn on your VCR and select its line input mode.

4 Set the Digital Camera **POWER** switch to **PLAY**. You may select manual or auto playback as described on pages 22 and 23.

- The LED Lamp lights up.

5 Start a recording of the desired images. (Refer to your VCR manual.)

Note:

- For extended periods of use, it is recommended to use the AC Adaptor for a power source.

Inserting the PCMCIA Adapter

If you are using a computer with a PCMCIA type II slot, you can insert the CompactFlash Card into a PCMCIA adapter (not included).

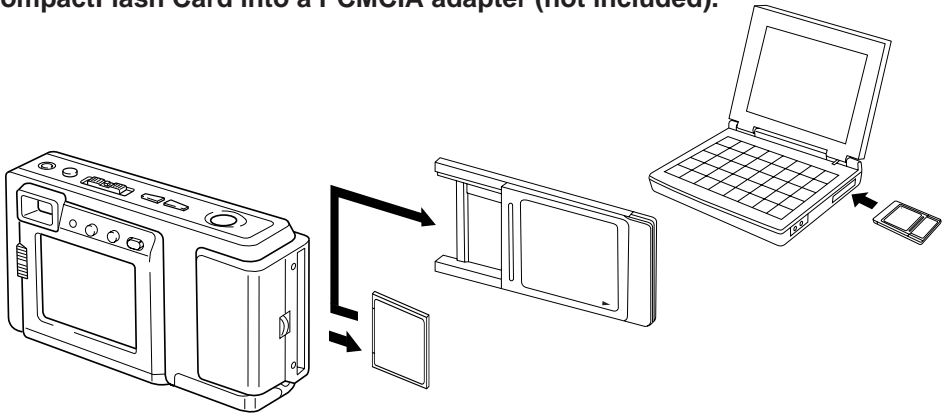

Inserting the CompactFlash Card

- The adapter should be inserted when your computer is in the power on mode.

- 1 Remove the CompactFlash Card from the camera. (See page 17.)
 - 2 Hold the CompactFlash Card so that the arrow side faces up and points toward the PCMCIA Adapter. Securely insert the card into the PCMCIA Adapter slot as far as it will go.
 - 3 Hold the PCMCIA Adapter so that the arrow side points toward the PCMCIA type II slot of your computer. Securely insert the PCMCIA Adapter as far as it will go.
- Depending on the computer, it may be necessary to turn the PCMCIA Adapter upside down in order to insert the card.

Removing the CompactFlash Card

- 1 Remove the PCMCIA Adapter from the computer.
- 2 Pull the CompactFlash Card out of the PCMCIA adapter.

Note

Do not remove the PCMCIA Adapter from the computer while the computer is working or while image data is being transferred between the CompactFlash Card and the computer (including operation such as opening and storing images), this will cause irreversible damage to the memory.

If Windows 95 Explorer is opened

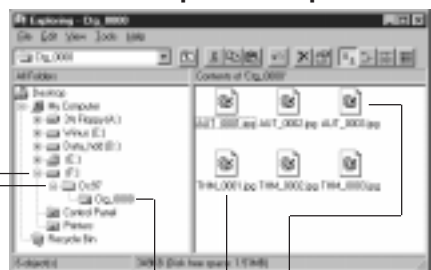

- Up to 50 images are stored in Ctgxxx folder
- Image Data is displayed as AUT_000x.jpg file
- Thumbnail files are displayed as THM_000x.jpg file (Contains no image data substance)
- Sub Directory (DC97)
- Identified as Removable Hard Disk

Transferring Your Images (Windows 95)

System Requirements:

- IBM PC/AT or compatible.
- Windows 95.
- 386SX CPU or higher. (486 recommended.)
- RAM: 16 MB on-board memory.
- 10 MB available hard disk space.
- 256 Color monitor or full color recommended (24bit per pixel or 16.7M color).
- CD-ROM drive (for installation).
- RS-232C serial port (D-Sub 9-pin). An adaptor is required for a D-Sub 25-pin.
- Mouse or other pointing device.

NikonView 600 Driver Installation

1 Turn on the PC (Personal Computer) and start up Windows.

2 Insert this disk into the CD-ROM drive.

3 Click the "Start" button and then click "Run"..



4 Type in "D:\Nview600\Setup.exe" and then click OK.

Note: "D" Denotes the CD-ROM drive designation.

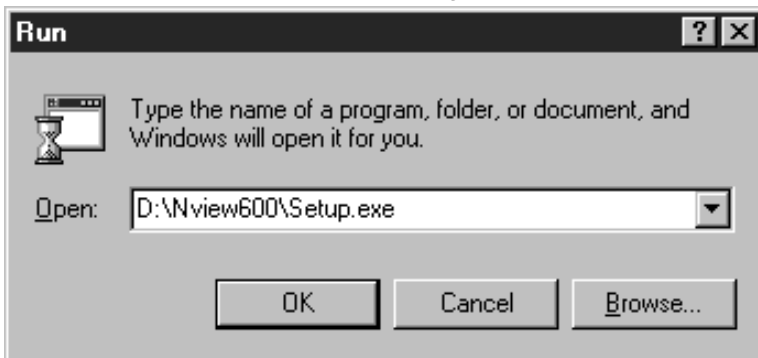

5 Follow the instructions as they appear on your PC screen.

Transferring Your Images (Windows 95)

Plug-in Driver for Adobe® PhotoDeluxe™ 2.0 Installation

- The Plug-in Driver, when installed, allows your camera to communicate directly with PhotoDeluxe 2.0.

Note:

- Please install Adobe PhotoDeluxe 2.0 before installing this driver.
- For information on Adobe PhotoDeluxe, please call 206-628-5724
Web Site : <http://www.adobe.com.supportservice/custsupport/main.html>

1 Turn on the PC (Personal Computer) and start up Windows.

2 Insert this disk into the CD-ROM drive.

3 Click the "Start" button and then click "Run".



4 Type in "D:\Plugin\Setup.exe" and click "OK".

Note: "D" Denotes the CD-ROM drive designation.

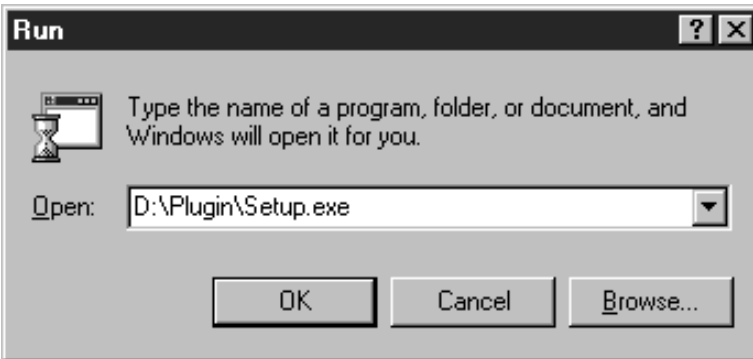

5 When installation is completed, start up PhotoDeluxe2.0 and follow the instructions on how to transmit images.

Transferring Your Images (Windows 95)

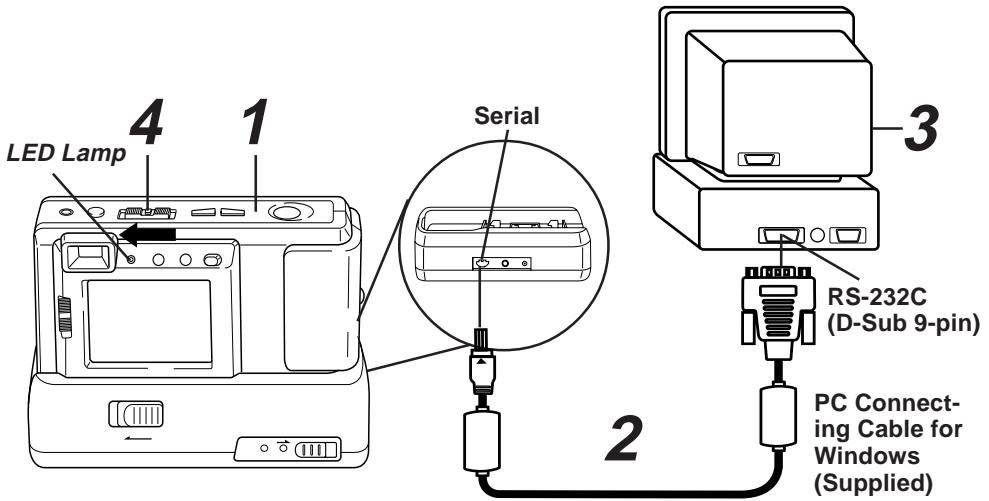

Connection

1 Insert the Digital Camera into the Digital Camera Station until it locks.

2 Connect the Digital Camera Station to your PC (Windows) using the PC connecting cable (supplied) with the arrow mark facing downward.

3 Turn on your PC.

4 Set the Digital Camera POWER switch to PLAY.

- The LED Lamp lights up.

Note:

- For extended periods of use, it is recommended to use the AC Adaptor as a power source.
- While the PC communicates with the Digital Camera, the Digital Camera cannot be operated.

Running the Application

5 Select Programs/Nikon View 600 1.0/ Nikon View 600 from the Start Menu.

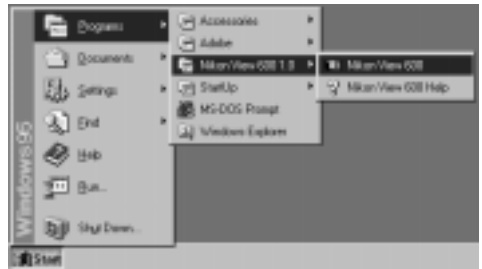

6 Please read the Help information fully before operating the application.

Transferring Your Images (Macintosh)

System Requirements:

- System 7.1 or later.
- 68030 CPU or higher, or Power Macintosh.
- 16 MB of RAM.
- 10MB available hard disk space.

NikonView 600 Driver Installation

- 1** Turn on the Macintosh.
- 2** Insert this disk into the CD-ROM drive.
- 3** Double click the CD-ROM icon.



- 4** Read the "Read Me" file.
- 5** Drag the "Nikon View 600" Folder where you want to copy.

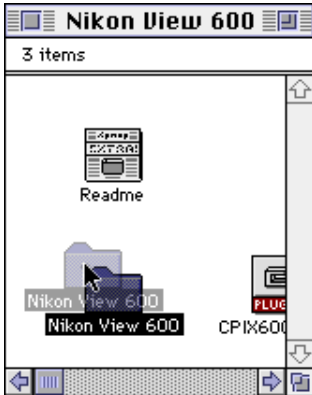

- 256 Color monitor or full color recommended (24bit per pixel or 16.7M color).
- CD-ROM drive (for installation).
- Modem port or printer port (RS-422).
- Mouse or other pointing device.

Plug-in Driver for Adobe® PhotoDeluxe™ 2.0 Installation

- The Plug-in Driver, when installed, allows your camera to communicate directly with PhotoDeluxe 2.0.

Note:

- Please install Adobe PhotoDeluxe 2.0 before installing this driver.
- For information on Adobe PhotoDeluxe, please call 206-628-5724
Web Site : <http://www.adobe.com.supportservice/custsupport/main.html>

- 1** Turn on the Macintosh.
- 2** Insert this disk into the CD-ROM drive.
- 3** Double click the CD-ROM icon.



- 4** Drag the "CPIX600.8bam" file to the "Plug-ins" folder of PhotoDeluxe.

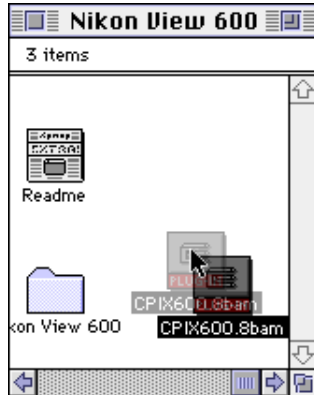

- 5** When installation is completed, start up PhotoDeluxe 2.0 and follow the instructions on how to transmit images.

Transferring Your Images (Macintosh)

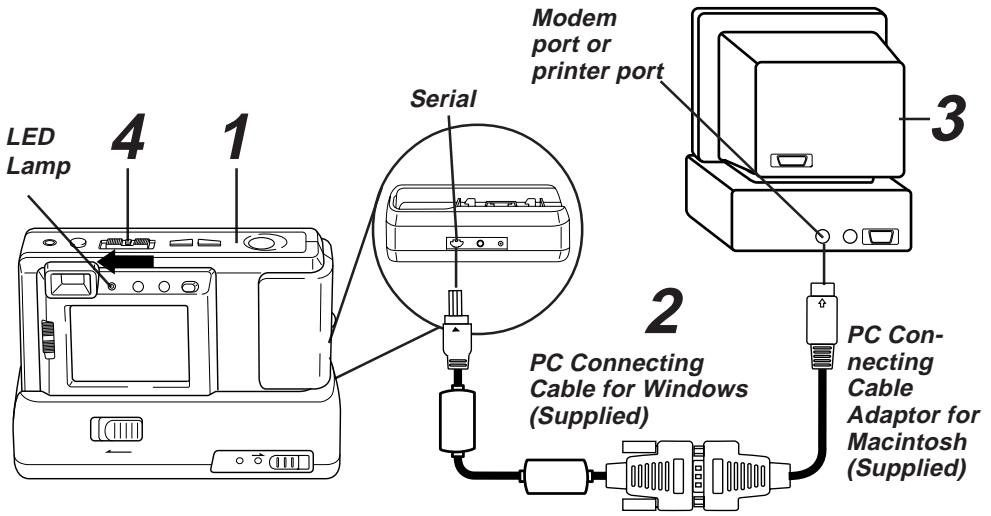

Connection

1 Insert the Digital Camera into the Digital Camera Station until it locks.

2 Connect the Digital Camera Station to your PC (Macintosh) using the PC connecting cable (supplied) and PC Connecting Cable Adaptor for Macintosh (supplied) with the arrow mark facing downward.

3 Turn on your PC (Macintosh).

4 Set the Digital Camera POWER switch to PLAY.

- The LED Lamp lights up.

Running the Application

5 Double click the Nikon View 600 icon.



Nikon View 600

6 Please read the Help file fully before operating the application.

Note:

- For extended periods of use, it is recommended to use the AC Adaptor as a power source.
- While the PC communicates with the Digital Camera, the Digital Camera cannot be operated.

Before Requesting Service

If you have a problem with your Digital Camera, it may be something you can correct yourself.

Check the list below for symptoms and corrections.

Symptom	Correction
Cannot charge the Battery Pack.	<ul style="list-style-type: none">• Make sure the rechargeable Ni-Cd Battery Pack is inserted. (p. 8)• Make sure all necessary connections are correct and tight. (p. 9)
No power.	<ul style="list-style-type: none">• Battery Pack is worn out. (p. 8)• Make sure polarities are aligned properly. (p. 8)• Make sure the rechargeable Ni-Cd Battery Pack is fully charged. (p. 9)
Power shuts off automatically.	<ul style="list-style-type: none">• Auto shut off feature is on. Press SHTR (SHUTTER), or set the POWER switch to OFF and then set to REC. (p. 20)
Cannot capture the image.	<ul style="list-style-type: none">• CompactFlash Card is not inserted. (p. 17)• Make sure the POWER switch is set to REC. (p. 19)• No memory. Delete some images before capturing images. (pp. 27, 28)
LCD Viewfinder image is too bright or dark.	<ul style="list-style-type: none">• Make sure the LCD Viewfinder brightness setting is adjusted. (p. 14)
Indication or image on the LCD Viewfinder is not focused.	<ul style="list-style-type: none">• Make sure the NORMAL/MACRO1/MACRO2 switch is properly set. (p. 21)
Cannot playback.	<ul style="list-style-type: none">• CompactFlash Card is not inserted. (p. 17)• There are no images in the memory. (p. 22)• Make sure the POWER switch is set to PLAY. (p. 22)
Auto Playback feature can not be performed.	<ul style="list-style-type: none">• There is only one image in the memory.
No picture on the TV (if connected).	<ul style="list-style-type: none">• Make sure all necessary connections are correct and tight. (p. 29)• Make sure the TV is set to video input mode. (p. 29)

Specifications

CCD	1/2.7 inch (9.3 mm) 1.08 million CCD (Approx. 800,000 pixels Usage)	
Lens	f=5.0 mm (equivalent to a 36 mm lens on a 35 mm still camera.)/F2.8	
Focus	Auto Focus with 2 Macro Position	
Shooting Distance	Normal: 19.7 inch (0.5m)—∞/Macro: 5.5 inch (14cm)/ 10.6 inch (27cm) (approx)	
Iris	F2.8/F11	
Shutter Speed	1/4–1/2,000 sec.	
White Balance	Auto White Balance (AWB)	
LCD Viewfinder	2 inch (50.8 mm) Po-Si TFT Color Liquid Crystal Display	
Storage Media	CompactFlash (CF) Card (8 MB)	
Image Size	1,024 × 768 pixels (Fine, Multi mode) 512 × 384 pixels (Normal, Zoom mode) 1,136 × 640 pixels (Wide mode)	
Storage Capacity	Approx. 30 images (Fine, Multi, Wide mode) Approx. 100 images (Normal, Zoom mode)	
Compression Format	JPEG (4:2:2, Exif)	
Interface	Serial (via Digital Camera Station)	
Video Output	NTSC Composite (via Digital Camera Station)	
Power Supply	Rechargeable Ni-Cd Battery / 2 AA Alkaline Battery *1 / 2 AA Lithium Battery *2 / 2 AA Ni-Cd Battery / 2 AA nickel-hydride Battery / AC Adaptor	
	*1 For emergency use only and when taking pictures with LCD Viewfinder turned off.	
	*2 In places where the temperature is 50°F(10°C) and below, the battery's characteristic use time is shortened. A exclusive nickel-cadmium battery pack is recommended in lower temperatures.	
Power Consumption	Digital Camera	2.4V DC, 1.3A (Ni-Cd Battery) 3V DC, 1.1A (Alkaline Battery)
	AC Adaptor	Input: 120V AC 60Hz 7W
	Digital Camera Station	3V DC, 1.3A
Operating Temperature	32 – 104 °F/0 – 40 °C	
Operating Humidity	10 % – 75 %	
Weight	Digital Camera	7.4 oz approx./210g approx.
	AC Adaptor	5.3 oz approx./150 g approx.
	Digital Camera Station	3.9 oz approx./110 g approx.
	Detachable Speedlight	1.0 oz approx./30 g approx.
Dimensions	Digital Camera	4.3 (W) × 2.4 (H) × 1.8 (D) inch 109.5 (W) × 60 (H) × 44.5 (D) mm
	AC Adaptor	2.0 (W) × 2.8 (H) × 0.8 (D) inch 50 (W) × 72 (H) × 20 (D) mm
	Digital Camera Station	4.7 (W) × 1.3 (H) × 1.9 (D) inch 120 (W) × 33.5 (H) × 49.5 (D) mm
	Detachable Speedlight	1.0 (W) × 2.4 (H) × 1.1 (D) inch 25 (W) × 60 (H) × 29 (D) mm

Weight and dimensions shown are approximate.
Design and specifications are subject to change without notice.

Index

A		M	
AC Adaptor	2, 6, 9, 10	MODE (Image Resolution)	18
Auto Playback	23	O	
Auto Power Off	20	On Screen Display (OSD)	16
B		OSD Off Mode	16
Battery Pack	2, 8, 9, 38	P	
Battery Remaining Indication	16	Playback	22, 23, 24, 25, 26
Brightness (LCD Viewfinder)	14	POWER Lamp (Digital Camera Station)	9, 10
C		S	
Capturing Close-up Images (macro)	21	Setting the Clock	11
Capturing Images	18, 19, 20	Soft Carrying Case	2, 7
Charging Battery Pack	9	Specifications	38
CompactFlash Card	2, 17, 31	Symptom/Correction	37
D		T	
Detachable Flash	2, 7, 12, 13	Transferring Images	30, 32, 33, 34, 35, 36
H		V	
Hand Strap	2, 7	Video Cable	2, 29, 30
I			
Iris	15		
L			
LIGHT Indication	16		

NIKON CORPORATION

Electronic Imaging Division
4-25, Nishi-Ohi 1-chome,
Shinagawa-ku, Tokyo 140, Japan

6ME 40000
Printed in Japan (9804)